

## PANEL RADIATORS IN AN INTEGRATED NATURAL OR MECHANICAL VENTILATION SYSTEM

*Muminov Oybek Alisher ugli*

*Doctorate, of the Fergana Polytechnic Institute Construction Faculty. Republic of Uzbekistan,  
o.muminov@ferpi.uz*

*Musajonov Muhammadrasul Alisher ugli*

*Master's student of the Fergana Polytechnic Institute Construction Faculty. Republic of Uzbekistan,  
muhammadrasulmusajonov@gmail.com*

### Abstract

The nozzle attached to the hole in the outer wall is attached to the bottom of the radiator is attached to the wall. The prefix allows the inflow of outside air, which heats up when passing between the radiator panels. Due to this, direct heating of the ventilation air is possible. This increases the heat output of the radiator compared to standard parameters.

### ARTICLE INFO

#### Article history:

Received 16 Oct 2022

Revised form 15 Nov 2022

Accepted 17 Dec 2022

**Key words:** Radiators, Mechanical.

© 2019 Hosting by Central Asian Studies. All rights reserved.

\*\*\*

**Introduction:** A wide range of panel radiator options can be made with different sizes and in different colors. The general principle of panel radiator Marking concerns the number of panels and fins, as well as the height of the radiator. As a rule, the first digit indicates the number of panels, and the second – the number of panels with fins (on one side). The next digit, usually preceded by a dash, indicates the height of the panel in centimeters. For example, a radiator marked 22-50 has two panels, both with ribs (on one inner side), the height of the panel is 50 cm.

Panel radiators can also be manufactured in special designs that provide increased resistance to corrosion of the external surface. This makes it possible to use them in rooms with high humidity or in places where the device can be in direct contact with water.

**Main body:** Usually the kit is equipped with air filters and, if necessary, an electric fan.

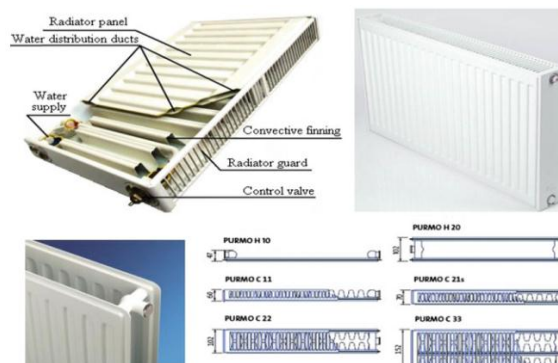

**Fig. 1. The device of panel and convectors-panel radiators on the example of the selected Purmo. Products**

Figure 1 shows the design of panel and panel-convector heating radiators and the typical marking of the most common models of such devices. A panel radiator with a ventilation attachment is shown in Fig. 2

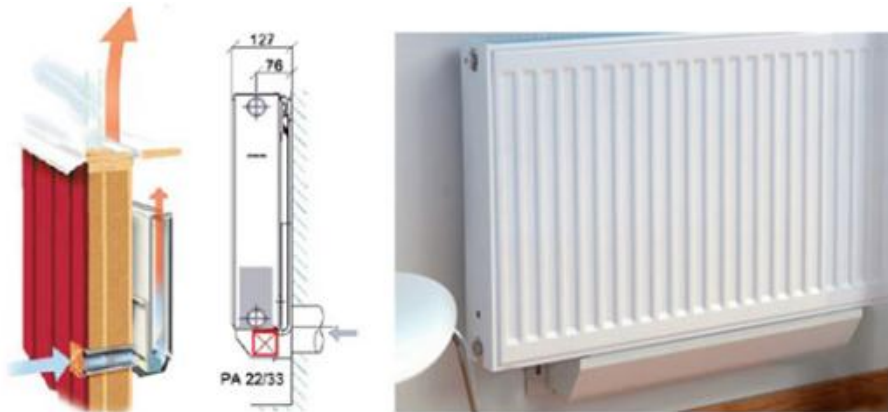

**Fig. 2 Panel radiator operating in a complex ventilation system**

Panel radiators have many advantages, the most important of which are:

- low specific gravity,
- low water capacity (about 3-4 times less than that of a cast-iron column radiators) and low thermal inertia,
- the possibility of obtaining any surface finish and shape,
- small geometric dimensions of the unit (according to a given heating capacity),
- the possibility of achieving thermal power with a high proportion of thermal power is formed due to radiation heat transfer,
- Easy access to heating surfaces and ease of cleaning (in the case of radiators without convective fins).

The disadvantages include:

- relatively high hydraulic resistances,
- sensitivity to corrosion.

The aforementioned advantages of panel and panel convector radiators have:

Made them very popular - currently they are the most common type of radiators used.

Their disadvantages seem significant only in the case of gravity and open

Installations, which are currently very rare. In typical properly functioning 2 systems, their importance is low.

Panel radiators are welded from two stamped corrosion-resistant sheets with a thickness of 1.4...1.5 mm using contact welding, a device of shallow depth and different lengths is formed. Convective finning is provided to increase the heating surface of the device. The profile of radiator blocks can have flat vertical channels 1, united by horizontal collectors 2 of the RSV-1 type in a single-row version (Fig. 3.a) and a double-row version of the RSV-1 type 2 (Fig. 3.b).

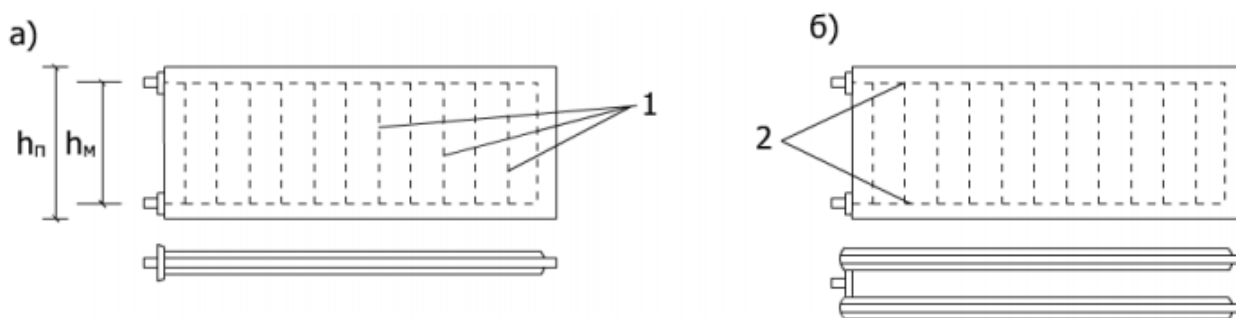

**Fig. 3. RSV type steel panel radiators: a – type RSV-1 in single row design; b – type 2 RSV-1 in double row design; 1 – vertical channels; 2 – horizontal collectors**

There is a variety of RSV type radiators made of low-carbon cold-rolled steel with a thickness of 1.4... 1.5 mm, produced of type RS-9 in single row and type 2 RSV-9 in double row without fins and with fins (2 RSV-9-K, 2 RSV-9-KK)

### Conclusions:

Currently, five types of radiators of RSV-3 type steel panel models are produced 10, 11, 20, 21, 22. For example, a type 22 device has two flat blocks (the first digit is 2) and two rows of fins (the second digit is 2), etc In addition, RSG-type steel panel radiators are produced, made of two stamped steel sheets with a thickness of 1.4 ... 1.5 mm, connected by contact welding and forming horizontal channels. Radiators are manufactured in single-row (RSG-1), double-row (RSG-2) and three-row (RSG-3) versions. Steel panel radiators are manufactured depending on the type with a length from 490 to 1660 mm, a height from 500 and above and are operated at a pressure from 0.6 to 1.9 MPa and a coolant temperature from 95 to 150°C.

### References:

1. Muminov, O. (2022). TYPES OF CAVITATION, CAUSING VIBRATION IN ENGINEERING AND WATER SUPPLY SYSTEMS. *Science and innovation*, 1(A7), 732-737.
2. Mo'minov, O. A., & O'tbosarov Sh, R. TYPE OF HEATING RADIATORS, PRINCIPLES OF OPERATION AND THEORETICAL ANALYSIS OF THEIR TECHNICAL AND ECONOMIC CHARACTERISTICS.
3. O'tbosarov, S., & Xusanov, N. (2022). ASSEMBLY OF STRUCTURES AND WATER DIVIDERS. *Science and innovation*, 1(A7), 780-784.
4. Mo'minov, O. A., Abdugarimov, B. A., & O'tbosarov, S. R. (2021). Improving support for the process of the thermal convection process by installing reflective panels in existing radiators in places and theoretical analysis. In *Наука и инновации в строительстве* (pp. 47-50).
5. Аббасов, Ё. (2020). Роль солнечных воздухонагревателей в теплоэнергетической отрасли и перспективы их развития в Республике Узбекистан. *Общество и инновации*, 1(1), 1-13.
6. Abbasov, E. S. (2004). Calculation of the turbulized boundary layer in diffusor-confusor solar receivers. *Applied Solar Energy*, 40(1), 92-94.
7. Abbasov, E. S. (2004). Heat exchange intensification in solar heat collectors of solar air heaters. *Applied solar energy*, 39(4), 20-23.
8. Mamatisaev, G., & Muulayev, I. (2022). ECOLOGICAL AND TECHNOLOGICAL PROBLEMS IN WATER COLLECTION FACILITIES. *Science and innovation*, 1(A7), 767-772.
9. Nasirov, I. (2022). АКТУАЛЬНОСТЬ ПРИМЕНЕНИЯ МЕТОДОВ МАТЕМАТИЧЕСКОГО МОДЕЛИРОВАНИЯ И МЕТОДОВ КОНЕЧНЫХ ЭЛЕМЕНТОВ В СТРОИТЕЛЬСТВЕ. *Science and innovation*, 1(A7), 711-716.

10. Nosirov, A. A., & Nasirov, I. A. (2022). Simulation of Spatial Own of Vibrations of Axisymmetric Structures. *European Multidisciplinary Journal of Modern Science*, 107-115.
11. Akramovna, U. N., & Ismoilovich, M. R. (2021). Flow Around a Plate at Nonzero Cavitation Numbers. *CENTRAL ASIAN JOURNAL OF THEORETICAL & APPLIED SCIENCES*, 2(12), 142-146.
12. Muminov, O., & Maksudov, R. (2022). HIDROTECHNICS PREVENT VIBRATIONS THAT OCCUR IN CONSTRUCTIONS. *Science and innovation*, 1(A7), 762-766.
13. Abdullayev, B. X., & Rahmankulov, S. A. (2021). Modeling Aeration in High Pressure Hydraulic Circulation. *CENTRAL ASIAN JOURNAL OF THEORETICAL & APPLIED SCIENCES*, 2(12), 127-136.
14. Abdullayev, B. X., & Rahmankulov, S. A. (2021). Movement of Variable Flow Flux Along the Path in a Closed Inclined Pipeline. *CENTRAL ASIAN JOURNAL OF THEORETICAL & APPLIED SCIENCES*, 2(12), 120-126.
15. Xamdaliyevich, S. A., & Rahmankulov, S. A. (2021, July). Investigation of heat transfer processes of solar water, air contact collector. In *E-Conference Globe* (pp. 161-165).
16. Husanov, N., & Abdukhalilova, S. (2022). HEAT EXCHANGE PROCESSES IN A SHELL-AND-TUBE HEAT EXCHANGER. *Science and innovation*, 1(A7), 721-725.
17. Maqsudov, R. I., & qizi Abdukhalilova, S. B. (2021). Improving Support for the Process of the Thermal Convection Process by Installing. *Middle European Scientific Bulletin*, 18, 56-59.
18. Abbasov, Y., & Usmonov, M. (2022). CALCULATION OF THEIR POWER AND HEATING SURFACE IN IMPROVING THE EFFICIENCY OF AIR HEATING SYSTEMS. *Science and innovation*, 1(A7), 738-743.
19. Usmonova, N. A. (2021). Structural Characteristics of the Cavern at a Fine Bubbled Stage of Cavitation. *Middle European Scientific Bulletin*, 18, 95-101.
20. Usmanova, N., & Abdukhalilova, S. (2022). SHELL-AND-TUBE HEAT EXCHANGER DESIGN WITH INCREASED TURBULENCE OF THE HEATED LIQUID FLOW. *Science and innovation*, 1(A7), 726-731.
21. Madaliyev, E., Makhsitalayev, B., & Rustamova, K. (2022). IMPROVEMENT OF SEWAGE FLATS. *Science and innovation*, 1(A7), 796-801.
22. Madaliyev, E., & Maksitaliyev, B. (2022). A NEW WAY OF GETTING ELECTRICITY. *Science and innovation*, 1(A7), 790-795.
23. Koraboevich, U. M., & Ilhomidinovich, M. G. (2021, June). Calculation of the free vibrations of the boxed structure of large-panel buildings. In " *ONLINE-CONFERENCES*" PLATFORM (pp. 170-173).
24. Mullaev, I. (2022). ҚУЁШ-ҲАВО ИСИТИШ ҚУРИЛМАСИНИНГ САМАРАДОРЛИГИНИ ОШИРИШ. *Science and innovation*, 1(A7), 756-761.
25. Abobakirovich, Abdukarimov Bekzod, Abbosov Yorqin Sodikovich, and Mullayev Ikromjon Isroiljon Ogli. "Optimization of operating parameters of flat solar air heaters." *Вестник науки и образования* 19-2 (73) (2019): 6-9.
26. Madaliev, M. E. U., Maksudov, R. I., Mullaev, I. I., Abdullaev, B. K., & Haidarov, A. R. (2021). Investigation of the Influence of the Computational Grid for Turbulent Flow. *Middle European Scientific Bulletin*, 18, 111-118.
27. Azizovich, N. I. (2022). On The Accuracy of the Finite Element Method on the Example of Problems about Natural Oscillations. *European Multidisciplinary Journal of Modern Science*, 116-124.

28. Abbasov, Y. S., & ugli Usmonov, M. A. (2022). Design of an Effective Heating System for Residential and Public Buildings. *CENTRAL ASIAN JOURNAL OF THEORETICAL & APPLIED SCIENCES*, 3(5), 341-346.
29. Ismailov, M., & Xolmatov, I. (2022). КАНАЛИЗАЦИЯ ТАРМОҚЛАРИНИ ЛОЙИХАЛАШНИНГ АПТИМАЛ УСУЛЛАРИ. *Science and innovation*, 1(A7), 744-749.
30. Рашидов, Ю. К. Орзиматов, Ж. Т., & Исмоилов, М. М. (2019). Воздушные солнечные коллекторы: перспективы применения в условиях Узбекистана. *ББК 20.1 я43 Э 40*.
31. Ismailov, M., & Xolmatov, I. (2022). OPTIMAL METHODS FOR DESIGNING SEWER NETWORKS. *Science and Innovation*, 1(7), 744-749.
32. Ибрагимова, З. К. К., Хамдамова, Н. С. К., Умуркулов, Ш. Х. У., & Сабиров, Д. Р. У. (2022). ПОДГОТОВКА ПИТЬЕВОЙ ВОДЫ ИЗ МАЛОМОЩНЫХ ПОВЕРХНОСТНЫХ ВОДОИСТОЧНИКОВ. *Central Asian Research Journal for Interdisciplinary Studies (CARJIS)*, 2(Special Issue 4), 77-83.
33. Madaliev, E. U., & qizi Abdukhalilova, S. B. (2022). Repair of Water Networks. *CENTRAL ASIAN JOURNAL OF THEORETICAL & APPLIED SCIENCES*, 3(5), 389-394.
34. qizi Abdukhalilova, S. B. (2021). Simplified Calculation of the Number of Bimetallic Radiator Sections. *CENTRAL ASIAN JOURNAL OF THEORETICAL & APPLIED SCIENCES*, 2(12), 232-237.
35. Madraximov, M. M., Nurmuxammad, X., & Abdulkhaev, Z. E. (2021, November). Hydraulic Calculation of Jet Pump Performance Improvement. In *International Conference On Multidisciplinary Research And Innovative Technologies* (Vol. 2, pp. 20-24).

